



Displayphone

User Guide

nt northern
telecom

Congratulations, you are among the first to experience one of the most advanced office communications systems yet developed... DISPLAYPHONE.

DISPLAYPHONE is an integrated business telephone and data terminal that offers convenience features and capabilities far beyond anything that has ever been available before in one unit.

As a business telephone it features on-hook dialing, last number re-dial, directory memory, automatic dialing, a recall worklist and handsfree capabilities.

As a data terminal it can be used to access both remote and local data services.

DISPLAYPHONE is capable of handling both voice and data calls at the same time, so you can talk to someone while accessing a data base and viewing information on the screen. It also offers other services... a continuous day/date clock, a telephone call timer and a reminder service that brings messages to your attention.

DISPLAYPHONE is self-instructing through its visual prompts and changing 'soft keys' that lead the user from one operation to another.

To derive the most benefit from all of the many features offered, this guide has been prepared in sections which provide step-by-step instructions for each operation.

It is recommended that you begin by setting up your display clock and telephone directory, and acquainting yourself with all of the other services and features that are available. This will allow more efficient use of the equipment as you work with the telephone and data sections of the guide.

You will find a convenient table of contents at the beginning of each section to help you locate instructions on how to perform specific functions. If at any time you need help, call your DISPLAYPHONE representative.

IMPORTANT

Before using DISPLAYPHONE it is necessary to set the signaling operation at the appropriate mode. Instructions for this setting can be found on page 11.

DISPLAYPHONE owners in the United States must comply with the Federal Communication Commission's rules and regulations. See page 38 of this manual for details.

How to use your DISPLAYPHONE

Quick Response Guide

Components

Installation

...as a Telephone Set

...as a Data Terminal

...for Special Services

Until you become familiar with DISPLAYPHONE, these instructions will help you to respond to the DISPLAYPHONE alerting signals.

IF YOU SEE OR HEAR...

FOLLOW THESE STEPS:

... **LINE 1 flashing and a warble tone:**

You have a call on line 1. To answer, lift the handset or talk handsfree.

... **LINE 2 flashing and a warble tone:**

You have a call on line 2. To answer, press LINE 2 key and lift the handset or talk handsfree.

... **SERVICES light flashing with or without a tone signal:**

You have a reminder message. To view the message, press the SERVICES key then press the number 1 on the dial pad.

... **Date and Time display flashing**

There has been a power failure. Reset the Date and Time (see page 36 for instructions).

NOTE: If power has been off for more than three days, the contents of DISPLAYPHONE memory may have been lost or distorted. See page 10 for instructions on how to clear memory.



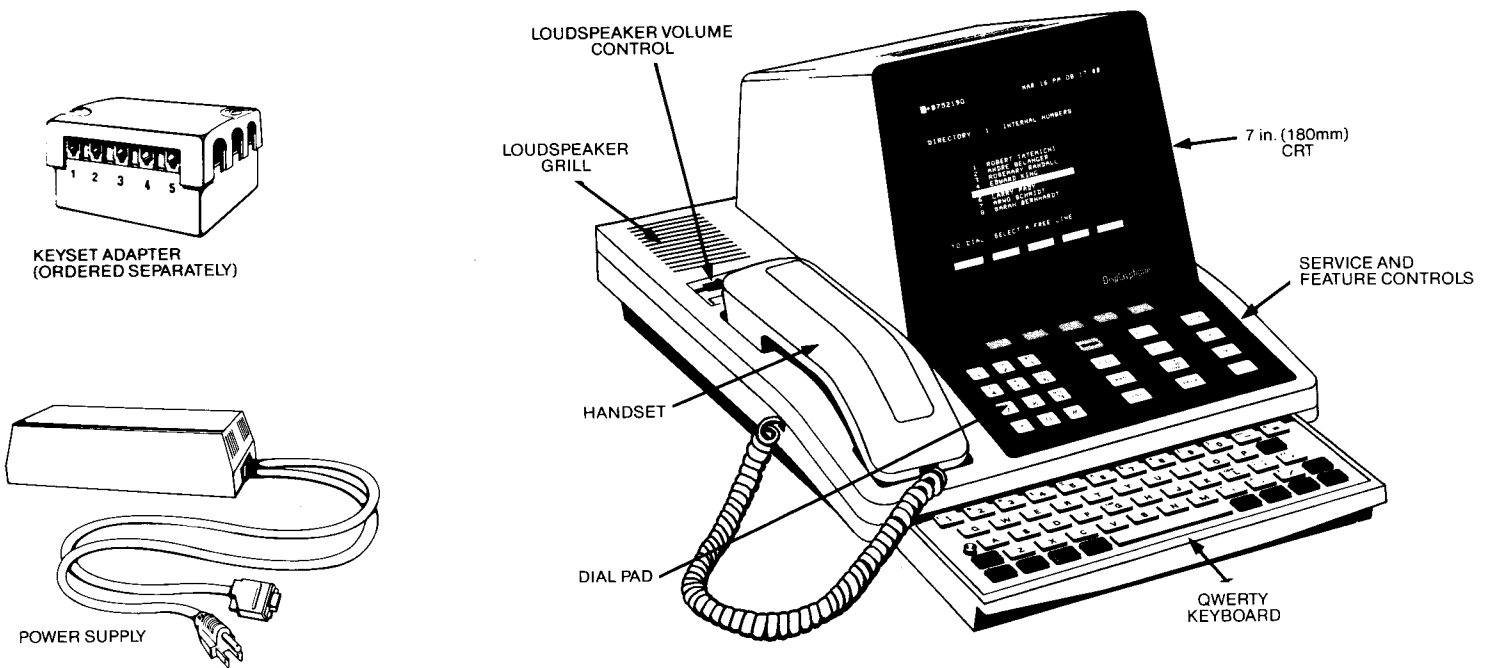
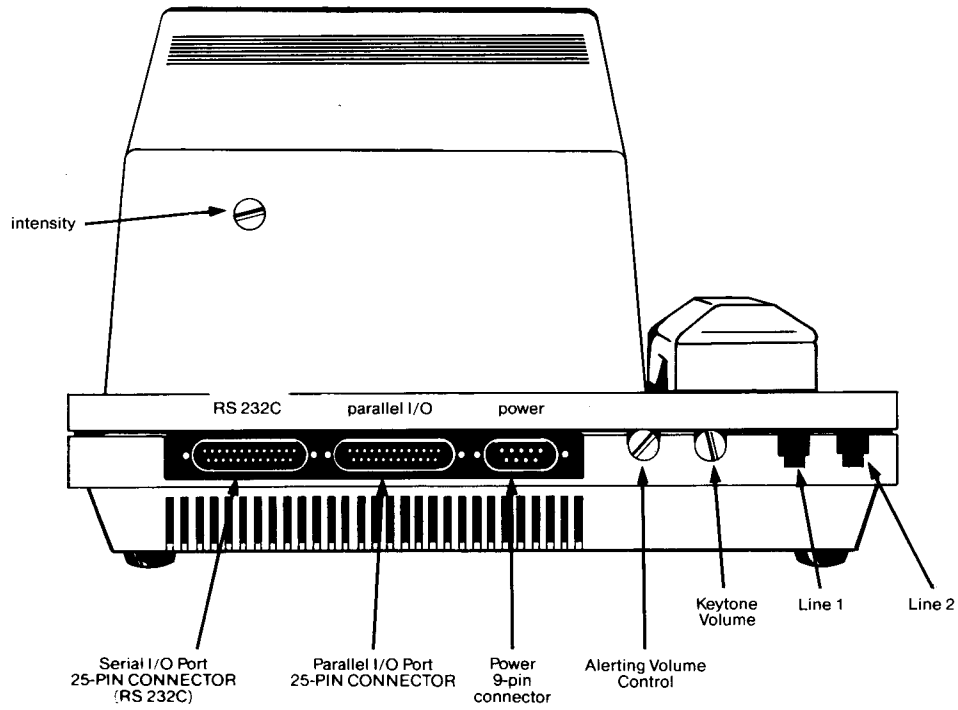

**HOW TO****PAGE**

—MAKE CONNECTIONS.....	8
—CLEAR THE MEMORY.....	10
—SET THE SIGNALING MODE.....	11
—SET THE DATE AND TIME.....	12

MAKE CONNECTIONS

The DISPLAYPHONE must be at room temperature before it is installed. Connect the DISPLAYPHONE as follows (see Figure 1 for connection details):

- 1) Connect the Handset to the jack located on the left side of the DISPLAYPHONE.
- 2) Connect line 1 and line 2 telephone line cords to your telephone system.
NOTE: Line 1 can be used only for voice communication. Line 2 can be used for voice or data communication. If only one telephone line is available, connect line 2 so that data calls can be made.
- 3) Connect the power supply. As soon as power is applied, your DISPLAYPHONE will turn on. After placing the 9-pin connector into the back of the DISPLAYPHONE, tighten the two screws on the connector to prevent disconnection of power to the unit.
NOTE: DISPLAYPHONE will not work as a telephone if the power fails or the unit is disconnected.
- 4) Connect the printer (if provided) to the PARALLEL I/O connector.
- 5) Connect the local computer or external modem (if provided) to the SERIAL I/O connector.

FIGURE 1 - DISPLAYPHONE CONNECTIONS

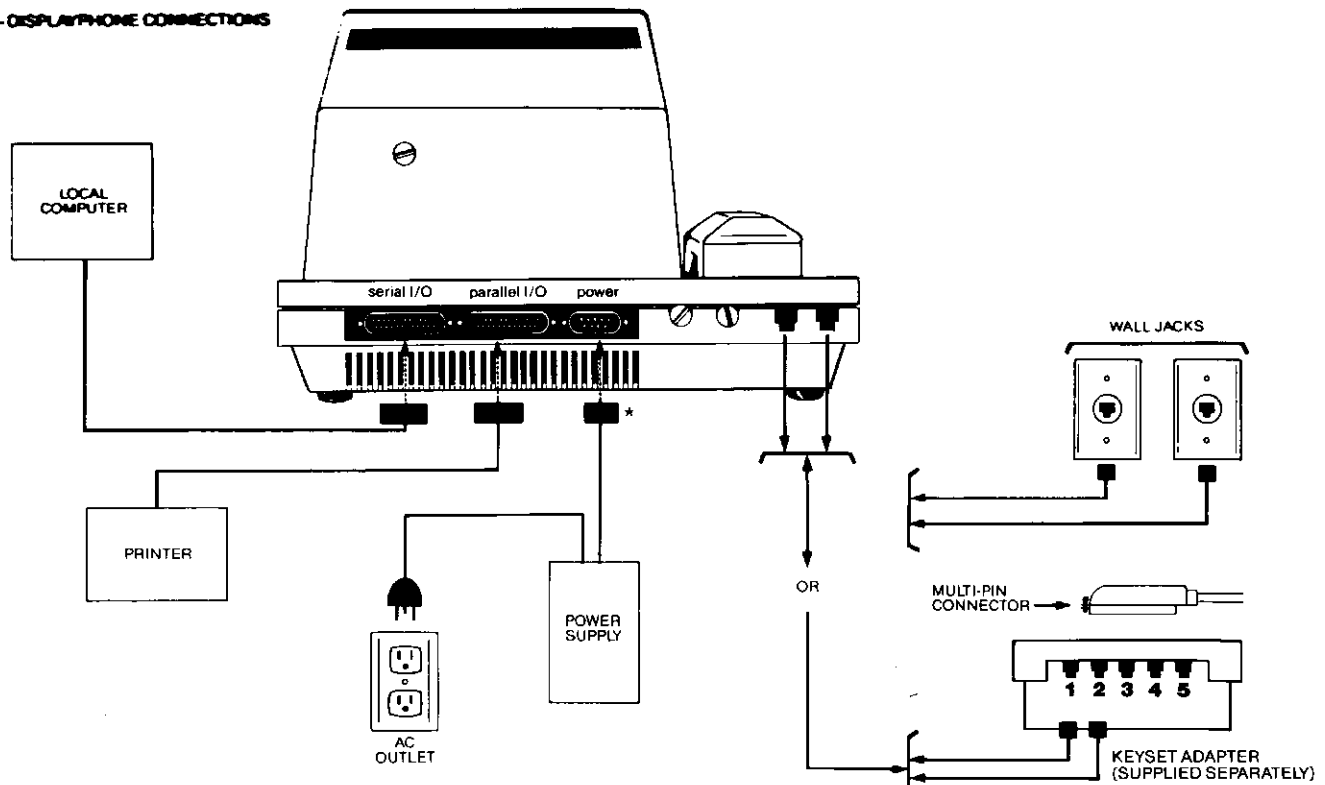

HOW TO CLEAR THE MEMORY

It is important that this procedure be undertaken when first installing DISPLAYPHONE. The only other time it may be necessary to clear the memory is if the DISPLAYPHONE has been without power for longer than three days. The memory contents may be lost or distorted. If you see unfamiliar characters in your Directory or Recall list, you should clear the memory.

- 1) Press the SERVICES key on the upper keyboard.
- 2) On the dial pad, press 0. The message 'PASSWORD' will appear on the screen.
- 3) On the dial pad, press 78. The following message will appear on the screen: TESTING RAM...

RAM PASSED TO: B7FFH

NEXT LOCATION

TEST VALUE = 00

VALUE READ = 80

NOTE: If this message does not appear, repeat the previous steps. If it still does not appear, contact your DISPLAYPHONE representative for assistance.

- 4) Press the SERVICES key to clear the screen.

HOW TO SET THE SIGNALING MODE

The signaling mode determines how your DISPLAYPHONE sends dial signals to telephone company equipment. The mode selected may be either DIGIPULSE* or DIGITONE* (tone signaling). The mode selected depends on the service provided by your telephone company.

- 1) Press the SERVICES key.
- 2) Press 4 on the dial pad. The DISPLAYPHONE UTILITY display will appear on the screen.
- 3) Press 4 on the dial pad. The SIGNALING display will appear on the screen with the soft key labels 'EXIT' and 'CHANGE'. The soft keys are located on the top row of the upper keyboard. Labels on the last line of the screen indicate the function they perform at any given time.
- 4) Press the 'CHANGE' soft key to change the signaling.
- 5) When you have selected the correct signal, press the 'EXIT' soft key to return to the DISPLAYPHONE UTILITY display.

*DIGITONE and DIGIPULSE are trademarks of Northern Telecom Limited

HOW TO SET THE DATE AND TIME

The date and time are displayed in the upper right corner of the screen. Your DISPLAYPHONE will keep accurate time up to one minute per month. Should a power failure occur, the date and time will flash to indicate they are incorrect until they are changed.

- 1) Press the SERVICES key then press 4 on the dial pad to access DISPLAYPHONE UTILITY index.
- 2) Press 1 on the dial pad to access the DATE and TIME display.
- 3) Enter the correct date and time and specify AM by pressing 'A' or PM by pressing 'P'. Soft keys can be used to move left or right if required.
- 4) Press the 'EXIT' soft key to store the information. The screen will now show the DISPLAYPHONE UTILITY index.



HOW TO...	PAGE
ANSWER A CALL	14
– Automatic Line Select Feature	14
MAKE A CALL	14
– Manually	14
– With Handset On-Hook	14
– Using Predial Feature	15
– Using the Directory	15
– Using a Number Stored In the Recall List	15
– Using Last Number Redial	16
PUT A CALL ON HOLD	16
– Manually	16
– Automatically	16
USE THE HANDSFREE FEATURE	17
– To turn The Handsfree Feature On	17
– To Use The Muting Feature	17
USE THE CALL TIMER	17
– To Reset The Call Timer	18
TERMINATE A CALL	18
– With the Handset	18
– with the RELEASE key	18

NOTE: For instructions on how to place a Data Call, refer to the section on how to use your DISPLAYPHONE as a Data Terminal (page 21).

...as a Telephone Set

**HOW TO ANSWER
A CALL**

To answer a call on either line 1 or line 2:

- 1) Press the line key which has the call (the light beside that key will be flashing).
- 2) The DISPLAYPHONE will automatically be in the HANDSFREE state (see page 17 for details on handsfree operation). For a private conversation, lift the handset.

**AUTOMATIC LINE
SELECT FEATURE**

Line 1 can be answered by simply lifting the handset as DISPLAYPHONE will automatically select line 1 except when line 2 is in use.

HOW TO MAKE A CALL...

DISPLAYPHONE has a unique touch-sensitive dial pad. Sharp objects such as pens, should not be used to dial telephone numbers.

... MANUALLY

- 1) Pick up the handset. Press a LINE key to make your call.
- 2) Dial the number on the dial pad. The number being dialed appears in the upper left corner of the screen.

**... WITH HANDSET
ON-HOOK**

This feature allows you to dial without having to lift the handset.

- 1) Press a free line.
- 2) Dial the telephone number
- 3) When the call is answered, talk handsfree or lift the handset.

**... USING PREDIAL
FEATURE**

The Predial feature allows you to check telephone numbers for errors prior to making calls.

- 1) Dial the number. The number appears in the upper left corner of the screen. To erase the entire number, press the CLEAR soft key. To erase a single digit, press the DELETE key on the upper keyboard.
- 2) Press a free line key. DISPLAYPHONE automatically dials the number.
- 3) When the call is answered, talk to the person handsfree, or lift the handset.

**... USING THE
DIRECTORY**

After having entered telephone numbers into the DISPLAYPHONE directory (see page 28 for instructions on setting up the directory), you can have a number dialed automatically by pressing only four keys.

- 1) Press the DIRECTORY key on the upper keyboard.
- 2) On the dial pad, select the category number which holds the number of the person you want to call.
- 3) On the dial pad, select the number corresponding to the person you want to call. The name will be highlighted, and the number stored with the name will appear in the upper left corner.
- 4) Press a free line key. DISPLAYPHONE automatically dials the number.

**... USING A
NUMBER STORED IN
THE RECALL LIST**

With the recall feature, frequently-called or temporary lists of telephone numbers can be stored in the Recall list. Manually dialed numbers or numbers dialed from the Directory may be stored in this list by simply pressing the KEEP soft key when it appears during dialing. Once stored, numbers can be found quickly and automatically dialed. The Recall list may be edited to enter names beside manually dialed numbers (see page 32 for instructions).

- 1) Press the DIRECTORY key. The Directory Index will appear on the screen with a RECALL soft key label in the bottom left corner.
- 2) Press the RECALL soft key to display the Recall list.
- 3) On the dial pad, press the number for the name you want to call. The name will be highlighted, and the number stored with the name will appear in the upper left corner.
- 4) Press a free line key. DISPLAYPHONE automatically dials the number.

... USING LAST NUMBER REDIAL

The Last Number Redial feature allows you to automatically call the last number dialed on either line 1 or line 2.

- 1) Press the REDIAL key on the upper keyboard. The last number dialed will appear in the upper left corner of the screen.
- 2) Press a free line key. DISPLAYPHONE automatically dials the number.

HOW TO PUT A CALL ON HOLD..

DISPLAYPHONE offers two ways of putting a call on hold: 'manually' or automatically.

... MANUALLY

Press the HOLD key on the upper keyboard. The light beside the line key you are using will flash to indicate that the line is on hold. Return to the call by pressing the line key.

... AUTOMATICALLY

While a call is in progress, press the free line key. The line you are leaving will automatically be placed on hold and the light beside that line key will flash. After terminating the call, return to the line on hold by pressing that line key. To put the second call on hold and return to the original call, simply press the line key for the first call. The hold condition automatically transfers to the other line.

HOW TO USE HANDSFREE FEATURE...

Your DISPLAYPHONE will automatically be in the Handsfree mode of operation when a call is placed with the handset on-hook. The light beside the HANDSFREE key will be lit.

... TO TURN THE HANDSFREE FEATURE ON

If you are using the DISPLAYPHONE handset and want to use the hands-free feature:

- 1) Press the HANDSFREE key then place the handset on-hook. You will hear the other party through the speaker and the other party will hear you when you talk at a normal level.
- 2) Set the volume to a comfortable listening level by adjusting the control above the handset.
- 3) To return to a private conversation, simply pick up the handset. The HANDSFREE light will go out.

... TO USE THE MUTING FEATURE

The Muting feature allows you to have a private conversation with people in the same room without allowing the person at the other end of the line to hear you.

- 1) To use the muting feature, press the HANDSFREE key. The HANDSFREE light will flash.
- 2) To turn Muting off, press the HANDSFREE key again.

THE CALL TIMER

The call timer display is located under the date and time. Your DISPLAYPHONE has separate call timers for line 1 and line 2. The call timer automatically starts about 8 seconds after the last digit has been dialed. You may reset the call timer to 00:00 at any time during the call. The call timer display disappears about 30 seconds after the call has been terminated.

**TO RESET THE
CALL TIMER...**

Press the 'TIMER' soft key. The call timer will reset to 00:00. If you have one call on hold and another in progress, the call timer will reset for the call in progress.

**HOW TO TERMINATE
A CALL...****...WITH THE
HANDSET**

To terminate a call when using the handset, simply hang up.

**...WITH THE
RELEASE KEY**

Calls may be terminated by pressing the RELEASE key on the upper keyboard.

HOW TO...	PAGE
SET UP THE DISPLAYPHONE TERMINAL PROFILE	20
– For Manually Dialed Calls.....	20
MAKE A DATA CALL	21
– Manually.....	21
– From the Directory.....	22
MAKE A DATA CALL AND A VOICE CALL AT THE SAME TIME	22
HOW TO USE THE SEMI AUTOMATIC LOG-ON FEATURE	23
– To Store Log-on Codes.....	23
– To Log On.....	23
CHANGE THE SCREEN WIDTH	23
USE THE SCREEN KEY	24
TERMINATE A DATA CALL	24
USE THE LOCAL DATA PORT	24
– To turn the Local Data Port off.....	25

...as a Data Terminal

USING DISPLAYPHONE AS A REMOTE TERMINAL

DISPLAYPHONE can be used as a fully operational data terminal to access remote data services which use a dial-up telephone network and support asynchronous 300 Baud terminals. Data calls can be made manually or from the Directory only on line 2.

USING DISPLAYPHONE AS A LOCAL DATA TERMINAL

Your DISPLAYPHONE can also be used as a local data terminal by connecting the local host computer to the RS 232C SERIAL I/O connector on the back of your unit.

NOTE: DISPLAYPHONE cannot be used as a remote terminal and a local terminal at the same time.

HOW TO SET UP DISPLAYPHONE TERMINAL PROFILE...

Before making a Data Call, the DISPLAYPHONE terminal profile must be set to match the characteristics of the data service being accessed.

...FOR MANUALLY DIALED DATA CALLS

- 1) Press the SERVICES key. The SERVICES index will appear on the screen.
- 2) Access DISPLAYPHONE UTILITIES by pressing ³7 on the dial pad.
- 3) Access MANUAL CALL PROFILE by pressing 2 on the dial pad. The page for setting up the Terminal Profile will appear on the screen with the following soft key labels:

- | | |
|-------|--|
| EXIT | used to save the profile data and return back to the DISPLAYPHONE UTILITY index. |
| ERASE | clears the field in which the cursor (the small square block on the screen) is currently positioned. |
| TAB | moves the cursor right one field. |
| LEFT | moves the cursor left one character. |
| RIGHT | moves the cursor right one character. |

4) Using the soft keys to move the cursor, set the page-width, page-mode, duplex-type and parity.

WIDTH Press 4 for 40 character screen width or 8 for 80 character.

MODE Press P for page mode or S for scroll mode.

DUPLEX Press F for full duplex operation or H for half duplex.

PARITY Press O for odd parity, E for even parity or M for mark parity.

5) Press the EXIT soft key to store the data. The DISPLAYPHONE UTILITY list will appear on the screen.

6) Press the SERVICES key to return to the SERVICES list.

This profile will be stored in DISPLAYPHONE'S memory and will apply to all manually dialed Data Calls and local data port operation until the profile is changed.

HOW TO MAKE A DATA CALL ... MANUALLY

1) Dial the number for the data service. The soft key label 'DATA' will appear on the bottom line of the screen.

2) Press the 'DATA' soft key.

3) Press line 2 key. The message ' WAITING FOR CARRIER TONE...' will appear on the screen after dialing is completed. When the host computer answers the call, you will hear two brief tones over the speaker and the message will disappear.

4) Log-on to your host computer using your personal codes.

5) When the data session is finished, log off the data service. DISPLAYPHONE will release the line when the service disconnects. If faster disconnection is preferred, logoff, press the line 2 key then press the RELEASE key.

... FROM THE DIRECTORY

- 1) Press the DIRECTORY key. The DIRECTORY INDEX will appear on the screen.
- 2) On the dial pad, press the number for the Directory page where you stored the data service number. The page will appear on the screen.
- 3) Press the number for the data service you want to call. The telephone number will appear in the upper left corner of the screen.
- 4) Press LINE 2 key. DISPLAYPHONE automatically dials the number. 'WAITING FOR CARRIER TONE...' will appear on the screen. When the call is connected, you will hear two brief tones and the message will disappear.
- 5) Log-on to the host computer using your personal codes.

HOW TO MAKE A DATA CALL AND A VOICE CALL AT THE SAME TIME

DISPLAYPHONE allows a Data Call and a Voice Call to be in progress at the same time. Calls can be placed and answered on line 1 without having to terminate a Data Call on line 2. Also, a Voice Call can be placed or answered, put on hold, and then a Data Call can be made.

- 1) Make a Data Call on line 2.
- 2) Once connection to the service is made, press the LINE 1 key. The light beside LINE 2 key will flash indicating the 'data hold' condition. The screen will clear.
- 3) Make a Voice Call on line 1.

Note: A voice call can be answered on line 1, while a data session is in progress on line 2, by simply pressing the line 1 key. The 'data hold' feature prevents the line from being disconnected.

- 4) Press the SCREEN key on the upper keyboard. The data display will appear on the screen and the call on line 1 will remain connected. You can input information into the data service using the lower keyboard and talk over line 1 at the same time.
- 5) To terminate the call on line 1, press the RELEASE key.

HOW TO USE THE SEMI-AUTOMATIC LOG-ON FEATURE...

6) To terminate the Data Call, log off the data service. DISPLAYPHONE will release line 2 when the service disconnects. If faster disconnection is preferred, logoff, press the line 2 key, then press the RELEASE key.

This feature can only be used for data service numbers stored in the Directory.

When you store a number for a dial-up data service in the Directory, you can also store the codes used to log-on. Once these codes are stored, the semi-automatic log-on feature is used to speed up the connection. For security, private codes can be entered manually during the semi-automatic log-on procedure.

... TO STORE LOG-ON CODES

- 1) When your Data Call is connected, press the 'LEARN' soft key. The soft key labels 'EXIT', 'MANUAL', 'PAUSE' and 'CANCEL' will appear.
- 2) Log-on to your host computer. To enter private information during the log on procedure, press the 'MANUAL' soft key, then enter the information. When you press 'RETURN' on the lower keyboard, automatic storage of the log-on codes can resume.
- 3) Press the 'EXIT' soft key when you want to stop storing the log-on codes.

... TO LOG ON

- 1) When the Data Call is connected, press the 'AUTOTX' soft key.
- 2) Press the 'SEND' soft key every time the data service requires a response to continue with the log-on procedure.

HOW TO CHANGE THE SCREEN WIDTH

The DATA SCREEN FORMAT feature allows you to select a screen width of 40 or 80 characters/line for the data session in progress. Note that if 80 characters/line is selected, the screen will not change width until the 41st character is received for display.

- 1) While a Data Call is in progress, press the SERVICES key. The SERVICE list will appear on the screen.

- 2) On the dial pad, press 4 to access DISPLAYPHONE UTILITY.
- 3) On the dial pad, press 3 to access DATA SCREEN FORMAT.
- 4) Press the 'CHANGE' soft key to change the data screen format to 40 or 80 characters/line.
- 5) Press the 'EXIT' soft key to return to the DISPLAYPHONE utilities list.
- 6) Press the SCREEN key to return to the data display.

HOW TO USE THE SCREEN KEY

With DISPLAYPHONE you can access the Directory, Services features or telephone features during a data session. When a feature is selected, the data service information on the screen is replaced by the display for the selected feature. To return to the data service display simply press the SCREEN key.

HOW TO TERMINATE A DATA CALL

To terminate a Data Call, enter the appropriate log-off command to the host computer. DISPLAYPHONE will automatically release the line when the host computer disconnects. If faster disconnection is required, log-off, press line 2 key, then press the RELEASE key.

HOW TO USE THE LOCAL DATA PORT

With DISPLAYPHONE, you can operate with a local computer connected to the SERIAL I/O port on the back of your unit. Connection to the local computer is controlled through the LOCAL DATA PORT feature which allows you to select the baud rate and to turn the port on or off. The TERMINAL PROFILE must be set for operation with the local computer.

- 1) Press the SERVICES key.
- 2) Press 3 on the dial pad to access the LOCAL DATA PORT feature.
- 3) Press the 'BAUD' soft key until the correct transmit and receive baud rates appear on the screen. DISPLAYPHONE can transmit and receive at 75, 150, 300, 600 and 1200 baud.

- 4) Press the 'ON/OFF' soft key to turn the local data port on.
- 5) Press the 'EXIT' soft key. The RS232 DATA PORT PROFILE will appear on the screen
- 6) Set up the terminal profile as required. (See page 20 for instructions). Press the 'EXIT' soft key to lock in the information. The DISPLAYPHONE UTILITY list will appear on the screen.
- 7) Press the SCREEN key and proceed to use DISPLAYPHONE as a local computer terminal.

**TO TURN LOCAL
DATA PORT OFF...**

- 1) Log off the local computer.
- 2) Press the SERVICES key.
- 3) Press the '3' key to access the LOCAL DATA PORT display.
- 4) Press the 'ON/OFF' soft key to turn the port off.
- 5) Press the 'EXIT' soft key.

HOW TO...	PAGE
USE THE DIRECTORY	28
– Setting Up Page Titles	28
– Adding entries to the directory for Voice Calls	29
– Adding entries to the Directory for Data Calls	30
– Inserting Entries into the Directory	31
– Changing an entry in the directory	31
– Deleting an Entry from the Directory	31
USE THE RECALL FEATURE	32
– Entering names into the Recall List	32
– Deleting single Items from the Recall List	33
– Clearing the Recall List	33
USE THE REMINDER FEATURE	34
– Storing a Reminder Message	34
– Viewing a Reminder Message	35
– Clearing Expired Messages	35
– Clearing Unwanted Messages	35
USE THE DOODLE PAD	35
SET THE DATE AND TIME	36
USE THE PRINTER	36
– Page Print	37
– Remote Print	37

...for Special Services

HOW TO USE THE DIRECTORY

Your DISPLAYPHONE directory is arranged into 9 pages which each can store up to 9 names and telephone numbers.

Before setting up your directory, it may be helpful to organize it on a sheet of paper first for easy referral and inputting.

First, select up to 9 general categories, for example:

- 1) Emergency Numbers
- 2) Inter-Office Numbers
- 3) Personal Numbers
- 4) Data Numbers
- 5) Etc.

Within each of these categories, select up to nine numbers that you want to place in the category. For example, in Category 1, Emergency Numbers could be:

- 1) Police
- 2) Fire
- 3) Doctor
- 4) Insurance Agent
- 5) Poison Control
- 6) Etc.

The same procedure would be followed for the other categories.

SETTING UP PAGE TITLES

- 1) Press the DIRECTORY key. The Directory Index will appear on the screen.
- 2) Press the CHANGE soft key.
- 3) Press the number for the page you want to name. The soft key titles 'EXIT', 'DELETE', and 'MODIFY' appear.
- 4) Press the 'MODIFY' soft key. The 'PAGE TITLE' edit field will appear on the screen along with the following soft key titles:

- EXIT use to lock in the information and to return to the Directory Index.
- ERASE use to erase everything right of the cursor position.
- TAB use to return to the beginning of the edit field.
- LEFT use to backspace one character.
- RIGHT use to move forward one character.

- 5) Using the lower keyboard, enter the page title.
- 6) Press the 'EXIT' soft key to return to the Directory Index. The new title will be in the index.
- 7) Repeat this procedure to name the rest of the Directory pages.

ADDING ENTRIES TO THE DIRECTORY FOR VOICE CALLS

New entries can be added to the bottom of the list on each Directory Page or a new entry can be inserted at the top of the list or between any two existing entries.

- 1) Press the DIRECTORY key to access the Directory Index.
- 2) Press the number for the page on which you want to make an entry. The contents of that page will appear on the screen and a new set of soft key labels will appear on the bottom line.
- 3) Press the 'CHANGE' soft key.
- 4) Press the 'ADD' soft key. Two edit fields (NAME AND NUMBER) will appear on the screen.
- 5) Using the lower keyboard, enter the name in the NAME field. Use the 'TAB' soft key to move to the NUMBER field.
- 6) Enter the telephone number in the NUMBER field. The field will hold up to 20 digits. Use the ENTER key on the upper keyboard to enter any pauses required in the dialing sequence. A '+' sign will appear in the number to represent the pause.
- 7) The screen automatically shows the call-type as 'VOICE'.
- 8) Press the 'EXIT' soft key to store the name and number. The screen will return to the directory page display.

**ADDING ENTRIES
TO THE DIRECTORY
FOR DATA CALLS**

- 1) Complete Steps 1 through 6 in 'ADDING ENTRIES TO THE DIRECTORY FOR VOICE CALLS'.
- 2) Change the call-type to 'DATA' by pressing the 'D' key on the lower keyboard.
- 3) Press the 'EXIT' soft key to store the name and number. The edit field 'PROFILE FOR THIS DATA CALL' will appear on the screen. The fields WIDTH, MODE, DUPLEX and PARITY appear with the following soft key labels:

EXIT	used to save the profile data and return to the Directory Page.
ERASE	clears the field in which the cursor is currently positioned.
TAB	moves the cursor right one field.
LEFT	moves the cursor left one character.
RIGHT	moves the cursor right one character.
- 4) Use the soft keys to move the cursor to each field. Enter the correct profile into each of the fields as follows:

WIDTH	enter '4' for 40 character screen width or '8' for 80 character.
MODE	enter 'P' for page mode or 'S' for scroll mode.
DUPLEX	enter 'F' for full duplex operation or 'H' for half duplex.
PARITY	enter 'O' for odd parity, 'E' for even parity or 'M' for mark parity.
- 5) Press the EXIT soft key to store the information and return to the Directory Page.

INSERTING ENTRIES INTO THE DIRECTORY

- 1) Access the directory page on which you would like the entry inserted.
- 2) Press the number of the entry where the new entry is to be inserted. That entry will be highlighted.
- 3) Press the 'CHANGE' soft key. The soft key labels 'EXIT', 'DELETE', 'INSERT' and 'MODIFY' will appear.
- 4) Press the 'INSERT' soft key. The NAME and NUMBER fields will appear.
- 5) Type in the name and number for the entry to be inserted and select a VOICE or DATA call.
- 6) Press the 'EXIT' soft key. With a VOICE call, the Directory Page will appear. With a DATA call, the terminal profile page will appear. Type in the terminal profile then press the 'EXIT' soft key to return to the Directory Page. The new entry is inserted and other entries are renumbered accordingly.

CHANGING AN ENTRY IN THE DIRECTORY

- 1) Access the directory page with the entry to be changed.
- 2) Press the number which corresponds to the entry to be changed. That entry will be highlighted.
- 3) Press the 'CHANGE' soft key. The soft key labels 'EXIT', 'DELETE', 'INSERT' and 'MODIFY' will appear.
- 4) Press the 'MODIFY' soft key.
- 5) Type the name, number and call type into the entry fields which appear.
- 6) Press the 'EXIT' soft key. With a VOICE call, the Directory Page will appear. With a DATA call, the terminal profile page will appear. Make the necessary corrections then press the 'EXIT' soft key to store the information and return to the Directory Page.

DELETING AN ENTRY FROM THE DIRECTORY

- 1) Access the directory page with the entry to be deleted.
- 2) Press the number which corresponds to the entry to be deleted. The selected entry will be highlighted.
- 3) Press the 'CHANGE' soft key. The soft key labels 'EXIT', 'DELETE', 'INSERT', and 'MODIFY' will appear.

cont.

- 4) Press the 'DELETE' soft key. The name and number of the selected entry will be deleted and the remaining entries will be renumbered accordingly.
- 5) Press the 'EXIT' soft key to return to the directory page.

HOW TO USE THE RECALL FEATURE

The Recall feature allows you to make up a list of frequently dialed telephone numbers. Numbers are placed into the Recall list simply by pressing the 'KEEP' soft key, which appears on the bottom line of the screen each time a telephone number is dialed. You can store up to 9 numbers in the list. When the Recall list is full pressing 'KEEP' will cause the message 'Sorry Recall List is Full' to appear. See page 15 for instructions on how to make a call using a number from the Recall list.

Should you decide to 'keep' a number dialed from the Directory, the name will appear in the Recall list. Upon selecting that entry, the number stored with it will appear in the upper left corner and the number can be automatically dialed. Numbers kept in the Recall list from manually dialed calls only show the number.

This section describes how to enter names beside manually dialed numbers stored in the Recall list, how to delete single items and how to clear the entire list.

ENTERING NAMES INTO THE RECALL LIST

- 1) Press the DIRECTORY key. The Directory index and the 'RECALL' soft key label will appear.

NOTE: 'RECALL' soft key will not appear until a number has been stored in the Recall list.

- 2) Press the 'RECALL' soft key. The Recall list will appear on the screen along with soft key labels 'EXIT' and 'CHANGE'.
- 3) Press the item number you want to change. The item selected will be highlighted.
- 4) Press the 'CHANGE' soft key. The soft key labels 'EXIT', 'DELETE' and 'MODIFY' will appear.

DELETING SINGLE ITEMS FROM THE RECALL LIST

- 5) Press the 'MODIFY' soft key. The name and number edit page will appear.
- 6) Type in the name. The appropriate number will be in the number field. Press the 'EXIT' soft key. The Recall list will re-appear on the screen with the name in place.
- 7) Press the 'EXIT' soft key to return to the Directory Index.

CLEARING THE RECALL LIST

- 1) Press the DIRECTORY key. The Directory index will appear on the screen and the soft key label 'RECALL' will appear in the lower left corner.
 - 2) Press the 'RECALL' soft key. The Recall list will appear on the screen along with soft key labels 'EXIT' and 'CHANGE'.
 - 3) Press the item number you want to change. The item selected will be highlighted.
 - 4) Press the 'CHANGE' soft key. The soft key labels 'EXIT', 'DELETE' and 'MODIFY' will appear.
 - 5) Press the 'DELETE' soft key. the revised Recall list will appear on the screen.
 - 6) Press the 'EXIT' soft key to return to the Directory Index.
-
- 1) Press the DIRECTORY key. The Directory index will appear on the screen and the soft key label 'RECALL' will appear in the lower left corner.
 - 2) Press the 'RECALL' soft key. The Recall list will appear on the screen along with soft key labels 'EXIT' and 'CHANGE'.
 - 3) Press the 'CHANGE' soft key. Soft key labels 'EXIT' and 'CLEAR' will appear.
 - 4) Press the 'CLEAR' soft key. The recall list is cleared.
 - 5) Press the 'EXIT' soft key to return to the Directory Index.

HOW TO USE THE THE REMINDER FEATURE

The Reminder Service allows you to store personal messages in the DISPLAYPHONE and program the time at which you are to be alerted. Your DISPLAYPHONE can store Reminder messages for up to one year.

STORING A REMINDER MESSAGE

- 1) Press the SERVICES key on the upper keyboard. The Service index will appear.
- 2) Press 1 on the dial pad to access Reminder Services. A list of Reminder messages (if any) will be displayed.
- 3) Press the 'CHANGE' soft key.
- 4) Press the 'ADD' soft key. A blank Reminder Message display will appear on the screen.
- 5) Using the lower keyboard, type your message into the MESSAGE field, then press the 'TAB' soft key to move to the TYPE field.
- 6) Specify the type of reminder signal you prefer by typing a 'D' for Display reminder (flashing SERVICES light), or a 'T' for tone reminder (flashing SERVICES light and tones over the loudspeaker). If you do not choose the reminder type, DISPLAYPHONE will automatically choose a tone reminder.
- 7) Press the 'EXIT' soft key. A 'REMINDER EXPIRY' display will appear.
- 8) Type in the month, day, hour, minute and second that you want to receive the Reminder.
- 9) Press the 'EXIT' soft key to store the information and return to the REMINDER index. Press the 'EXIT' soft key to return to SERVICES.

VIEWING A REMINDER MESSAGE

When the preset time arrives, you will be alerted that the reminder message is due by a flashing light beside the SERVICES key. In addition, you may have also programmed an alerting tone, which you will hear over the speaker. You can view the reminder messages at any time.

- 1) Press the SERVICES key.
- 2) Press 1 on the dial pad. The reminder messages stored will appear.
- 3) Press the 'EXIT' soft key to return to the SERVICES index.

CLEARING EXPIRED MESSAGES

- 1) Press the SERVICES key.
- 2) Press 1 to access Reminder Services. The expired messages will be flashing.
- 3) Press the 'CHANGE' soft key.
- 4) Press the 'CLEAN' soft key. All expired messages will be erased.
- 5) Press SERVICES key to clear the screen.

CLEARING UNWANTED MESSAGES

- 1) Press the SERVICES key.
- 2) Press 1 on the dial pad.
- 3) On the dial pad, press the number for the message you want to delete. The message will be highlighted on the screen.
- 4) Press the 'CHANGE' soft key.
- 5) Press the 'DELETE' soft key. The message disappears.
- 6) Press the 'EXIT' soft key to return to the SERVICES index.

HOW TO USE THE DOODLE PAD

The DOODLE PAD feature allows you to type messages onto the DISPLAYPHONE screen.

- 1) Press the SERVICES key. The SERVICES index will appear on the screen.
- 2) On the dial pad, press 2. The screen will clear.

- 3) Using the lower keyboard and the dial pad, create whatever messages you require. The screen will show what you are typing. If your DISPLAYPHONE has been connected to a printer, you may print the information on the page.
- 4) The Doodle Pad does not retain information and all entries are erased when you leave the Doodle Pad. However, when DISPLAYPHONE is attached to a printer, the screen display can be printed using the Page Print instructions below. Press the 'EXIT' soft key to leave the DOODLE PAD and return to SERVICES.

HOW TO SET THE DATE AND TIME

The date and time are displayed in the upper right corner of the screen. Your DISPLAYPHONE will keep accurate time up to one minute per month. Should a power failure occur, the date and time will flash to indicate they are incorrect until they are changed.

- 1) Press the SERVICES key then press 4 on the dial pad to access DISPLAYPHONE UTILITY.
- 2) Press 1 on the dial pad to access the DATE and TIME display.
- 3) Enter the correct date and time and specify AM by pressing 'A' or PM by pressing 'P'. Soft keys can be used to move left or right if required.
- 4) Press the 'EXIT' soft key to store the information. The screen will now show the DISPLAYPHONE UTILITY index. You can clear the screen by pressing the SERVICES key.

HOW TO USE THE PRINTER

If you have a printer connected to your DISPLAYPHONE, you can control its activities through commands entered on the lower keyboard.

The printer may be used for remote Data Calls or with the Local Data Port.

In addition, the printer may be used to copy the Directory, Reminders, or any information entered on the screen with the DOODLE PAD feature. Two modes of operation are available.

PAGE PRINT

To Print a static screen display:

- 1) Simultaneously press the AUX SHIFT key and the '1' key on the lower keyboard.
- 2) To stop printing, simultaneously press the AUX SHIFT key and the '3' key on the lower keyboard.

REMOTE PRINT

To print information while it is being received from a data service:

- 1) Simultaneously press the AUX SHIFT key and the '2' key on the lower keyboard.
- 2) To stop the print at any time, simultaneously press the AUX SHIFT key and the '3' key on the lower keyboard.

FEDERAL COMMUNICATIONS COMMISSION REQUIREMENTS, REGISTRATION AND WARNINGS

The following information applies to DISPLAYPHONE users in the United States only.

Your DISPLAYPHONE has been granted a registration number by the FEDERAL COMMUNICATIONS COMMISSION, under Part 68 Rules and Regulations, for direct connection to the telephone lines. In order to comply with these FCC rules, the following instructions must be carefully read and the applicable portions must be followed completely.

- 1) Direct connection to the telephone lines may be made only through standard plug-ended cords furnished to the utility-installed jacks. No connection may be made to party or coin phone lines. Prior to connecting the device to the telephone lines, you must:
 - Call your telephone company and inform them that you have an FCC registered device you desire to connect to their telephone lines.
 - Give them the number(s) of the line(s) to be used.
 - Give them the make and model number of the device, the FCC registration number, the ringer equivalent, and the kind of jack required (Jacks—USOC RJ11 RJ14/Ringer Equivalence = 0.5A 1.6B).
- 2) After the telephone company has been advised of the above, you may connect your device if the jacks are available, or after the telephone company has made the installation.
- 3) If you permanently disconnect any of the telephone equipment you use, you must notify the telephone company.
- 4) Repairs to the device may be made only by the manufacturer or his authorized service agency. This applies at any time during and after the warranty. If such unauthorized repair is performed, registration, connection to the telephone lines and the remainder of the warranty period all become null and void.
- 5) If through abnormal circumstances, harm to the telephone lines is caused, it should be unplugged until it can be determined if your device

or telephone line is the source. If your device is the source, it should not be reconnected until necessary repairs are effected.

- 6) Should the telephone company notify you that your device is causing harm, the device should be unplugged. The telephone company will, where practicable, notify you that temporary discontinuance of service may be required. However, where prior notice is not practicable, the telephone company may temporarily discontinue service if such action is reasonably necessary. In such cases, the telephone company must:
 - a) promptly notify you of such temporary discontinuance.
 - b) Afford you the opportunity to correct the condition.
 - c) Inform you of your rights to bring a complaint to the FCC under their rules.
- 7) The telephone company may make changes in its communication facilities, equipment, operations or procedures, where such action is reasonably required in the operation of its business and is not inconsistent with FCC rules. If such changes can be reasonably expected to render any customer's devices incompatible with telephone facilities, or require modification or alteration, or otherwise materially affect its performance, written notification must be given to the user to allow uninterrupted service.

WARNING:

This equipment generates, uses and can radiate radio frequency energy and if not installed and used in accordance with the instructions manual, may cause interference to radio communications. It has been tested and found to comply with the limits for Class A computing devices pursuant to Subpart J of Part 15 of FCC Rules, which are designed to provide reasonable protection against such interference when operated in a commercial environment. Operation of this equipment in a residential area is likely to cause interference in which case the user, at his own expense, will be required to take whatever measures may be required to correct the interference.



DISPLAYPHONE...
the latest concept in Business Communications

KEY FUNCTIONS

SOFT KEYS

The soft keys are positioned on the keyboard so that they line up with labels that appear on the bottom line of the screen. The soft keys assume the functions of the labels when they appear on the screen for the different features. If a soft key has no label, pressing it has no effect.

DIAL PAD

The dial pad is used to enter telephone numbers, access numbers for the Directory, Recall and Reminder lists, and may also be used to enter numerical data.

SCREEN PAD

When a data session is in progress, the SCREEN key is used to return to the data display after a DISPLAYPHONE feature was used which causes the data display to clear.

REDIAL KEY

The REDIAL key causes the last number dialed to be displayed in the upper left corner of the screen. Pressing a free line key causes the number to be dialed.

DELETE KEY

The DELETE key is used to delete numbers dialed using the Predial feature. Each time the key is pressed, the cursor backspaces once and erases one character.

ENTER KEY

The ENTER key may be used to enter pauses (indicated by '+' in the display) when entering numbers in the Directory. During a data session, the ENTER key performs a carriage return function.

SERVICES KEY

The SERVICES key is used to display the Services list from which the various services can be accessed. Pressing the SERVICES key a second time causes the screen to clear.

DIRECTORY KEY

The DIRECTORY key is used to display the Directory index. Pressing the key a second time causes the screen to clear.

HANDSFREE KEY

The HANDSFREE key is used to turn the Handsfree feature on. Once the feature is activated, the HANDSFREE key is used to turn the Muting feature on and off.

RELEASE KEY

The RELEASE key is used to release a busy line when a call is being terminated. The line will return to the idle state.

ON/OFF KEY

The ON/OFF key is used to turn the screen on or off.

LINE 2 KEY

The LINE 2 key is used to access line 2 for making or answering a call. Line 2 can be used to make data calls.

LINE 1 KEY

The LINE 1 key is used to access line 1 for making or answering a call.

HOLD KEY

The HOLD key is used to place a busy line on hold.

(soft key) (soft key) (soft key) (soft key) (soft key)

1	abc 2	def 3	screen	services	on/off
ghi 4	jkl 5	mno 6	redial	directory	line 2
prs 7	tuv 8	wxy 9	delete	mute hands- free	line 1
*	0	'#	enter	release	hold

(page)	(on-line)	(off)	\	~		<	>	[]	{	}
1	2	3	4	5	6	7	8	9	0	-	=
Q	W	E	R	T	Y	U	I	O	P	return	
Ⓞ	A	S	D	F	bell G	H	J	K	clear L	: ;	" ,
shift	Z	X	C	V	B	N	M	< ,	> .	? /	shift
ctrl ctrl	aux shift	escape delete	break					↓	↑	←	→



Displayphone is a trademark of Northern Telecom Limited

DISPLAYPHONE software and firmware are copyrighted and are the proprietary and trade secret information of Northern Telecom Limited. Use, reproduction or publication of any portion of this material, without the prior written authorization of Northern Telecom Limited is strictly prohibited.

Information subject to change since Northern Telecom reserves the right, without notice, to make changes in equipment design or components as progress in engineering or manufacturing methods may warrant.

PRINTED IN CANADA
FEBRUARY 1982

REVISION LEVEL A
PO 622944 3179/11

CHANGES REQUIRED TO DISPLAYPHONE USER GUIDE (REVISION LEVEL A)

PAGE NO.	SECTION DESIGNATION	EXISTING	CHANGE TO
10	How to clear memory	Value Read = 80	Value Read = FF
21	How to make a Data Call manually	3) 'WAITING FOR CARRIER TONE . . .' will appear on the screen after dialling is completed.	3) 'DATA PAGE APPEARS IF CARRIER RECEIVED' will appear on the screen.
22	. . . from the Directory	4) 'WAITING FOR CARRIER TONE . . .'.	4) 'DATA PAGE APPEARS IF CARRIER RECEIVED'.
23	. . . to store log on codes	1) The soft key labels 'EXIT', 'MANUAL', 'PAUSE' and 'CANCEL' will appear	1) The soft key labels 'EXIT', 'MANUAL' and 'PAUSE' will appear. b) The 'CANCEL' soft key will appear after a log on code has been sent (eg. user types a carrier return). The 'CANCEL' soft key disappears once the first character of the next log on code is typed. The 'CANCEL' soft key is employed to delete incorrect log on codes from user memory, during the learn sequence.

TO: INSTALLER

PLEASE WIPE DOWN SCREEN OF DISPLAYPHONE
AS THE PROTECTIVE ANTI-STATIC BAG LEAVES
A FILM.

MANUFACTURING DEPARTMENT